

Installation and Programming Instructions for PhoneLink 50 and PhoneLink 500



Model 16-2050 & 16-2500



American Access Systems, Inc.

YOUR PARTNER IN ACCESS CONTROL

Table of Contents

FCC REQUIREMENTS	4
DOC REQUIREMENTS	5
Important Tips	6
Installation	6
(SYSTEM CONNECTIONS)	7
30-027 Circuit Board Layout	11
PhoneLink 50 System Intercom	12
Operation:	12
PhoneLink 50 Keypad	13
GOODBEEPS & ERRORBEEPS	14
UNIT RESET	15
PROGRAMMING	16
Sub-Mode 1 (Program Relay A Access Codes)	16
Sub-Mode 2 (Delete Codes)	17
Sub-Mode 3 (Change Master Code)	17
Sub-Mode 4 (Set Sleep Code and/or Latch Code)	17
(Set Latch Code)	18
Sub-Mode 5 (Set One Shot Code)	18
Sub-Mode 6 (Set Relay Output Times)	19
Sub-Mode 7 (Program Relay B Access Codes)	19
Sub-Mode 8 (Enable/Disable 3 Strikes-You're Out)	19
Sub-Mode 9 (Program Event Input)	20
Sub-Mode 0 (Erase all codes)	21
Support	22

AAS 2-Year Limited Warranty

What item(s) this warranty applies to:

American Access Systems "PhoneLink 50" line of access controls.

What is covered:

Any defect in materials or workmanship.

For how long:

Two years from date of purchase.

What we will do:

If your AAS product is defective and returned within 2 years of the date of purchase, we will repair it or, at our option, replace it at no charge to you. If we repair your AAS product, we may use new or reconditioned parts. If we choose to replace your AAS product, we may replace it with a new or reconditioned one of the same or similar design. The repair or replacement will be warranted for (a) 90 days or (b) the remainder of the original two year warranty period, whichever is longer.

Limitations:

Implied warranties, including those of fitness for a particular purpose and merchant ability (an unwritten warranty that the product is fit for ordinary use), are limited to two years from date of purchase. We will not pay for loss of time, inconvenience, loss of use of your AAS product, service calls, or property damage caused by your AAS product or its failure to work, or any other incidental or consequential damages. Some states do not allow limitations on how long an implied warranty lasts or the exclusion or limitation of incidental or consequential damages, so the above exclusions or limitations may not apply to you.

What we ask you to do:

To get warranty service for your AAS product, you must provide proof of the date of purchase. Contact the original dealer or installer of the product and return your AAS product along with the receipt to them. If you have problems locating the dealer or installer contact American Access Systems at (303) 799-9757 and we will direct you to an authorized dealer or distributor of American Access Systems products. If you ship your AAS product, you must prepay all shipping costs. We suggest that you retain your original packing material in the event you need to ship your AAS product. On return, include your name, address, phone number, proof of date of purchase, and a brief description of the operating problem.

What this warranty does not cover:

This warranty does not cover defects resulting from accidents, damage while in transit, alterations, unauthorized repair, failure to follow instructions, misuse, fire, flood, and acts of God. Nor do we warrant your AAS product to be compatible with any particular external device or peripheral. If your warranty has expired on your AAS product or if your product is NOT covered contact your dealer or installer for advice on whether we will repair your AAS product and other repair information, including estimated repair costs and other charges. We, at our option, may replace rather than repair your AAS product with a new or similar design if the damage to the unit is severe or extensive. This warranty is the only one we give on this product, and it sets forth all our responsibilities regarding your AAS product. There are no other express warranties.

State Law rights:

This warranty gives you specific legal rights, and you may also have other rights which vary from state to state.

**AMERICAN ACCESS SYSTEMS, INC.
7079 SOUTH JORDAN ROAD / UNIT 6
ENGLEWOOD, CO. 80112
PH: (303) 799-9757
FAX: (303) 799-9756**

FCC REQUIREMENTS

1. This equipment complies with Part 68 of the Federal Communications Commission Rules. On the inside panel of this equipment is a label that contains, among other information, the FCC registration number, Facility Interface code (FIC) and Service Order Code (SOC). This information must be provided to the telephone company.

Registration No: US: AAAOT01B30027

FIC: 02LS2

SOC: 9.0Y

USOC: RJ11C

2. This device complies with Part 15 of the FCC rules. Operation is subject to the following conditions:
1) This device may not cause harmful interference and 2) This device must accept any interference received, including interference that may cause undesired operation. Modification of the device by the user may cause the device to operate in violation of the FCC Rules.
3. The REN is used to determine the quantity of devices that may be connected to the telephone line. Excessive RENs on the telephone line may result in the devices not ringing in response to an incoming call. Typically, the sum of RENs should not exceed five (5.0). To be certain of the number of devices that may be connected to a line (as determined by the total RENs) contact the local telephone company.
4. An FCC-compliant telephone and modular plug is provided with this equipment. This equipment is designed to be connected to the telephone network or premises wiring using a compatible modular jack which is Part 68 compliant. See installation instructions for details.
5. If this equipment causes harm to the telephone network, the telephone company will notify you in advance that temporary discontinuance of service may be required. But, if advance notice is not practical, the telephone company will notify the customer as soon as possible. Also, you will be advised of your right to file a complaint with the FCC if you believe it is necessary.
6. The telephone company may make changes in its facilities, equipment, operations, or procedures that could affect the operation of the equipment. If this happens, the telephone company will provide advance notice in order for you to make necessary modifications in order to maintain uninterrupted service.
7. If trouble is experienced with the PhoneLink unit please contact American Access Systems, Inc. 1-800-541-5677. If the equipment is causing harm to the network, the telephone company may request you to remove the equipment from the network until the problem is resolved.
8. No repairs are to be made by you. Repairs are to be made only by American Access Systems, Inc. or its licensees. Unauthorized repairs void registration and warranty.
9. This equipment cannot be used on public coin service provided by the telephone company. Connection to Party Line Service is subject to state tariffs. (Contact the state public utility commission, public service commission or corporation commission for information.)

DOC REQUIREMENTS

Equipment Attachment Limitations

Notice: This equipment meets telecommunications network protective, operational and safety requirements as prescribed in the appropriate Terminal Equipment Technical Requirements Document(s). This is confirmed by marking the equipment with the Industry Canada certification number. The Department does not guarantee the equipment will operate to the users satisfaction.

Before installing this equipment, users should ensure that it is permissible to be connected to the facilities of the local telecommunications company. The equipment must also be installed using an acceptable method of connection. The customer should be aware that compliance with the above conditions may not prevent degradation of service in some situations.

Repairs to certified equipment should be coordinated by a representative designated by the supplier. Any repairs or alterations made by the user to this equipment, or equipment malfunctions, may give the telecommunications company cause to request the user to disconnect the equipment.

Users should ensure for their own protection that the electrical ground connections of the power utility, telephone lines and internal metallic water pipe system, if present, are connected together. This precaution may be particularly important in rural areas. **Caution:** Users should not attempt to make such connections themselves, but should contact the appropriate electric inspection authority, or electrician, as appropriate.

Notice: The Ringer Equivalency Number (REN) assigned to each terminal device provides an indication of the maximum number of terminals allowed to be connected to a telephone interface. The termination on an interface may consist of any combination of devices subject only to the requirement that the sum of the Ringer Equivalency Numbers of all the devices does not exceed five.

The abbreviation, IC, before the registration number signifies that registration was performed based on a Declaration of Conformity indicating that Industry Canada technical specifications were met. It does not imply that Industry Canada approved the equipment.

Important Tips

1. Your PhoneLink 50 contains static sensitive components. Proper grounding techniques should be exercised during installation to prevent damage to circuit board.
2. Additional surge protection is highly recommended to provide extra lightning protection.
3. Please follow the instructions in this manual carefully to prevent problems during installation and programming.
4. **Electrical Safety Advisory Notice:**
American Access Systems, Inc. recommends the installation of an AC surge arrester in the AC outlet from which the equipment is powered.

U.S. Service Center:
American Access Systems, Inc.
7079 S. Jordan Rd. # 6
Englewood, CO 80112
Phone: 1-800-541-5677

Installation

1. Proper wire size is necessary for a good and trouble-free installation. Follow the tables below for your installation.

DC Power Wire Size	Distance (in feet)	AC Power Wire Size
18 AWG	30' or less	18 AWG
18 AWG	30' to 75'	16 AWG
18 AWG	75' to 150'	12 AWG
16 AWG	150' to 250'	10 AWG
12 AWG	250' to 500"	N/A

Wiring from PhoneLink 50	Type of Wire	Recommended
To the 12V AC/DC power source	2 conductor cable	18 gauge stranded
To gate operator, door strike, or magnetic strike	2 conductor cable	Device manufacturer specs
To strike power supply (if used)	2 conductor cable	Device manufacturer specs
To earth ground	12 awg copper wire	Belden #9912

Wiring from Bypass Board	Type of Wire	Recommended
To Telco Box	18 to 24 Gauge twisted pair shielded	Belden #9502
To PhoneLink 50 Controller	18 to 24 Gauge twisted pair shielded	Belden #9502

2. Mounting the unit to your own pedestal
Your unit comes with a square mounting flange found in the bottom of the box along with four carriage bolts and four hex nuts. The square mounting flange may be welded to your pedestal and the flange bolt pattern will align with the unit. Place the unit up to the flange and insert the four carriage bolts from the backside. Secure the unit to the flange.

3. Mounting the unit to an AAS gooseneck pedestal (18-001) or double height gooseneck (18-003).
Locate the four carriage bolts and four hex nuts found inside the unit box. Place the unit up to the pedestal flange and insert the four carriage bolts from the backside. Secure the unit to the pedestal. The extra square mounting flange may be discarded.

(SYSTEM CONNECTIONS)

Wiring diagrams for your unit are presented on pages 9 & 10. Usually, you will be interfacing the unit to the Central Office or Telco Box. Carefully study the diagram which best suits your particular installation.

4. The diagram on page 9 shows hook-up using a bypass switch. American Access highly recommends using this type of installation. If the PhoneLink 50 is struck by lightning or some other heavy electrical surge the end user can simply switch to BYPASS to resume normal telephone operation.

5. Both diagrams show a RJ-12 test port on the PhoneLink circuit board. This can be used by field technicians to trouble-shoot problems by plugging a standard RJ-11 jack phone into the test jack. This is very helpful when working alone.

6. Both diagrams also show an EVENT terminal block on the PhoneLink circuit board. American Access recommends using this feature to switch

the night light using a dry-contact device such as a loop detector, electric eye, motion sensor etc. This will greatly extend the life of the light. More information can be found on page 15 under programming Event Input.

7. The PhoneLink 50 can be installed to a PBX or Key phone system. Connect two wires from a UNUSED CO port of the PBX system to To Phones terminal block on the PhoneLink 50 circuit board. Move jumper from Normal to PBX (*see Diagram on page 11 for jumper location*)
8. Connect your Access Device (gate operator, door strike, etc.) to Relay A or Relay B on the PhoneLink 50 (*see Diagram on page 11 for relay location*). In most installs this relay will connect to the OPEN circuit of a gate operator or connect in series with a DOOR STRIKE power lead. Consult your access device documentation for proper hook-up.
9. Relay Terminals are:
 - Com – Relay Common
 - N/C - Relay Normally Open
 - N/O - Relay Normally Closed

Standard Hook-up Diagram for PhoneLink 50 with Bypass Switch

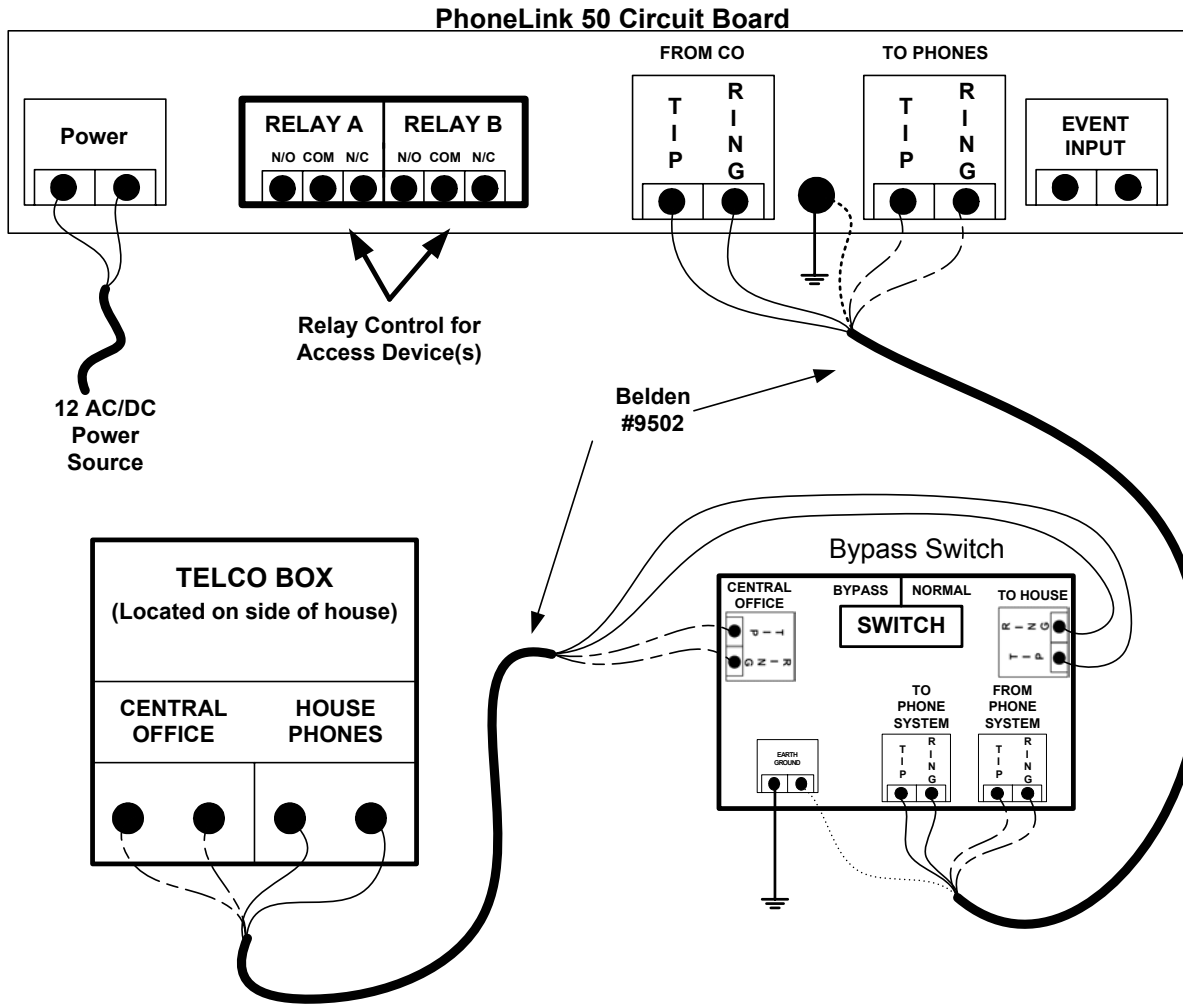

PhoneLink 50 Circuit Board	Bypass Switch	Telco Box
From Co	To Phone System	---
To Phones	From Phone System	---
---	Central Office	Central Office
---	House Phones	To Phones

= Earth Ground
 Shield Wire

Standard Hook-up Diagram for PhoneLink 50 without Bypass Switch

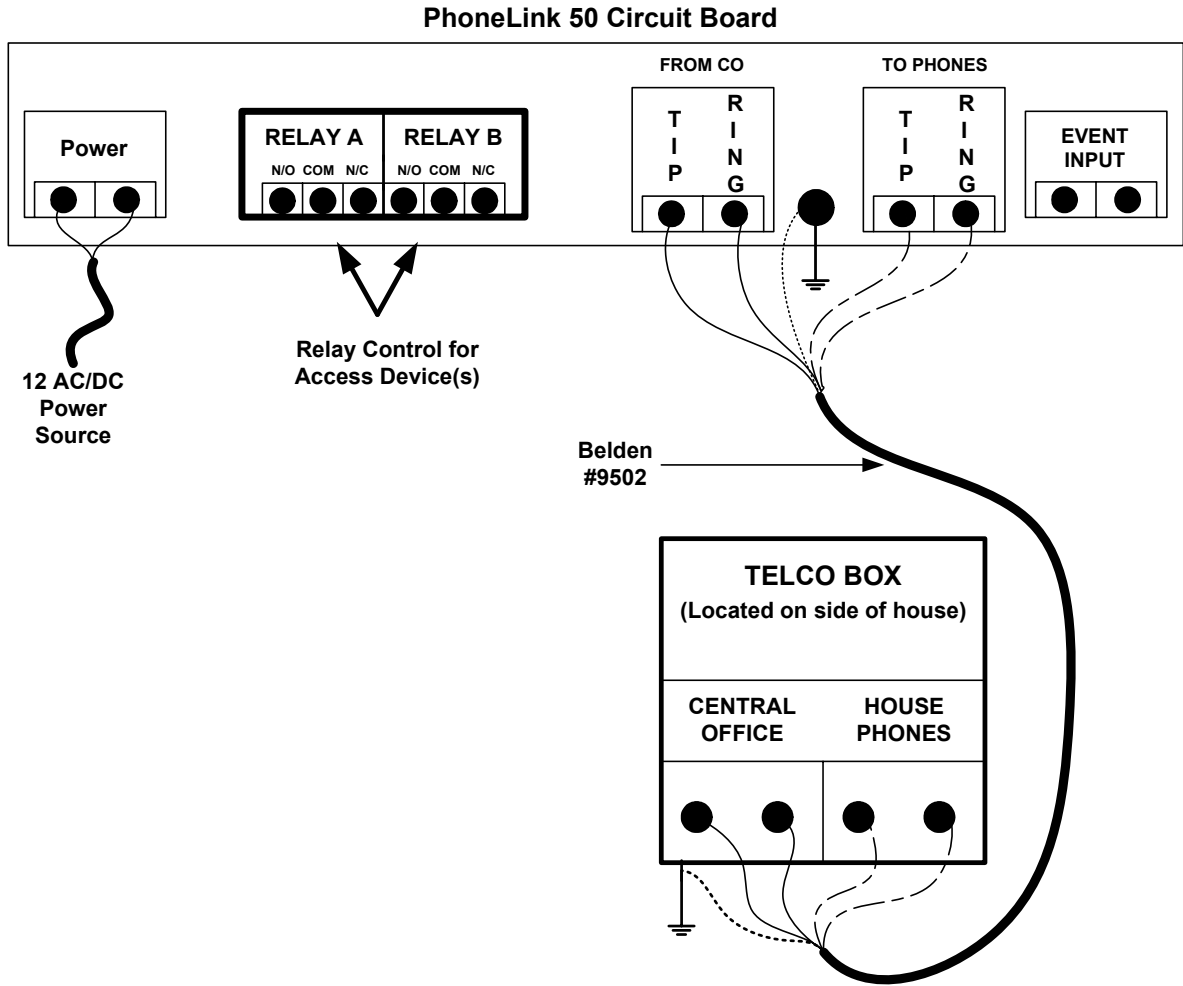

PhoneLink 50 Circuit Board	Bypass Switch	Telco Box
From Co	---	Central Office
To Phones	---	House Phones



30-027 Circuit Board Layout

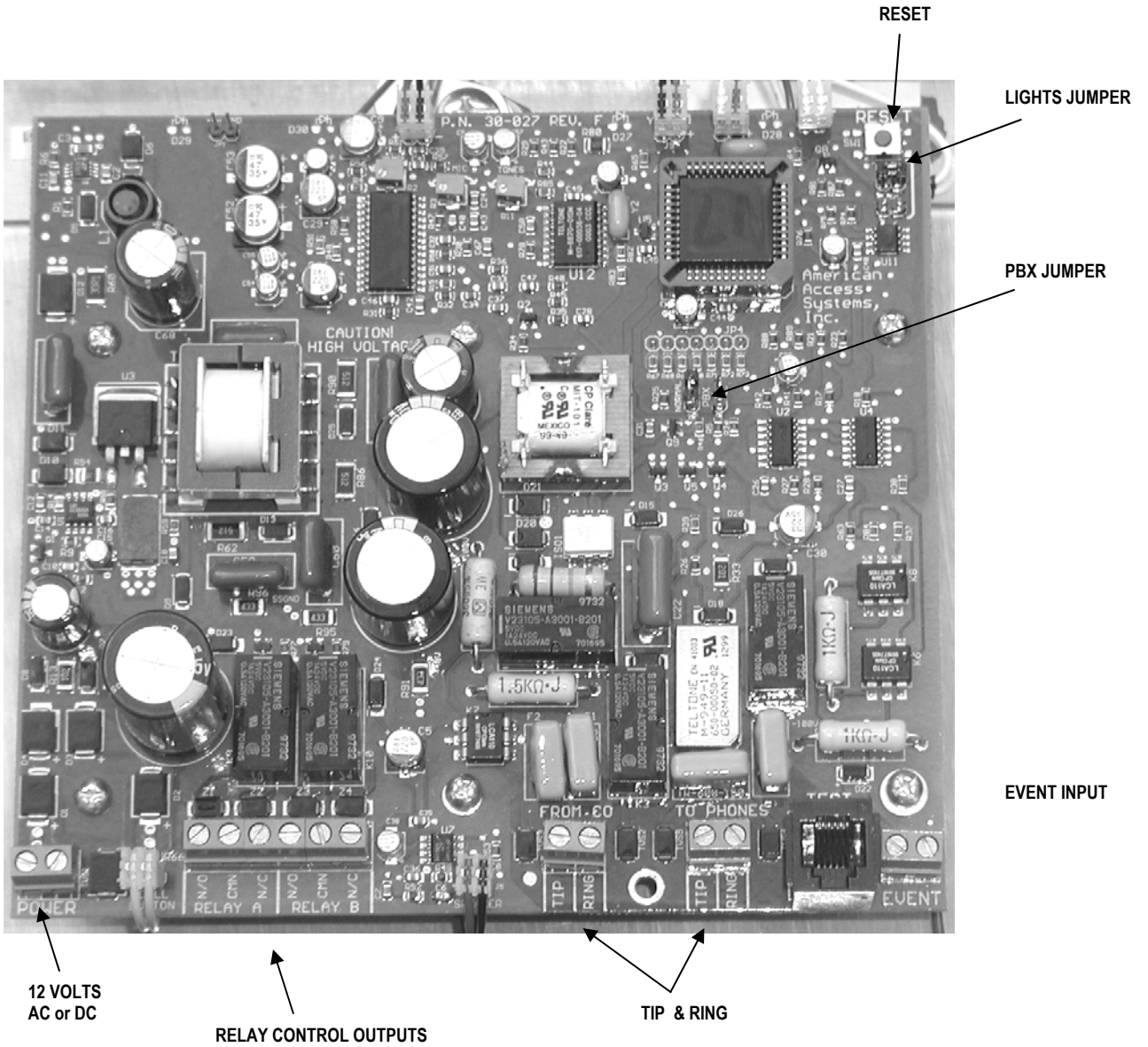

PhoneLink 50 System Intercom

Operation:

A visitor desiring access will push the call button on the outside control station, causing a special ring signal to be sent to the inside phone. Picking up the phone before 10 rings are completed will establish intercom mode between the house and the control station. The control station will respond with a *GOOD BEEP*. Hanging up the phone terminates intercom mode. If the house phone is already ringing because of a call from the central office when the call button is pressed a busy signal is sent to the control station speaker.

Call Waiting:

If the phone is already in use when the call button is pressed, a tone (similar to the central office "call waiting tone") will be heard, indicating the control station is calling. To place the central office line on hold press the "**#**" key within 15 seconds of the first tone. The control station will respond with a *GOOD BEEP* and establish intercom mode between the house and the control station.

The "**#**" key can be used to switch back and forth between the central office and intercom mode. However, the control station will only stay on hold for 15 seconds before it resets to idle mode.

If the central office tries to ring the house while the system is in intercom mode, the same call waiting tone will be heard. To switch to the incoming call press the "**#**" key.

Calling a Gate:

The house phone can call the gate to establish intercom mode. To do this simply lift the receiver and press "**# 1**" within 15 seconds. The control station will respond with a *GOOD BEEP* and establish intercom mode. If intercom mode is exited because of a call waiting switch, the house will have to hang up and call the gate again to re-establish intercom mode. (The "**#**" key cannot be used to get back to intercom mode if the house called the gate.)

Intercom Mode:

Once intercom mode is established, the house phone is connected to the speaker and microphone on the control station. Commands to control the gate can be given from the house phone. To activate relay A press "*** 1**" or "*** ***".

To activate relay B press “ * 2 ”. A single beep will be heard after the relay has been activated. To toggle the latch mode press the star key followed by the pound key (“ * # ”). The control station will respond to the toggle-latch-mode command with a single beep if the gate is now latched open, and a double beep if the gate is now closed. To toggle the sleep mode press “ * 9 ”. The control station will respond to the toggle-sleep-mode command with a single beep if the unit is now in sleep mode, and a double beep if the unit is not in sleep mode. Since sleep mode and latch mode are mutually exclusive, trying to activate one of those modes while the other is active will cause an *ERROR BEEP*. To toggle the one-shot enable press “ * 5 ”. The control station will respond to the toggle-one-shot-enable command with a single beep if the one-shot code is now enabled, and a double beep if the one-shot code is now disabled. Hanging up the phone terminates intercom mode. Intercom mode is also terminated after five minutes of inactivity --- i.e. five minutes after the last gate command, or five minutes after it is started if no gate commands are given.

Intercom mode and use of the keypad are mutually exclusive: if someone is in the middle of entering a four digit code on the keypad (i.e. after the first numeric key is pressed, and until the operation finishes), the call button will not work and the house cannot call the gate. If the call button has been pressed, or the house has called the gate, the keypad will not work until the system is back in idle mode. The remote open mode for the event input will work while the unit is in all modes except program mode.

PhoneLink 50 Keypad

ACCESS & FUNCTION CODES

Depending on which model you have, your unit may be programmed with multiple (4 digit) access codes, the number of access codes is reflected in the model number. There are two different types of codes, access codes & function codes. Although the number of access codes will vary with each model, the number of function codes is always 4.

FUNCTION CODES

"MASTER CODE"

This code is a programmable four digit code used for gaining access to the program mode. **It does not activate the control relay.** The factory default master code is 1 2 5 1.

"LATCH CODE"

This code is a programmable four digit code used to toggle relay A. This code will be used to hold open a gate or door.

"SLEEP CODE"

This code is a programmable four digit code which when entered, will disable all codes. When the "*SLEEP CODE*" is entered again the unit will be enabled. An override code is provided.

"ONE SHOT CODE"

This code is a programmable four digit code that disables itself after one use. The user can enable this code for reuse using the keypad or telephone.

GOODBEEPS & ERRORBEEPS

Your unit will beep each time a key is pressed. The "*" key serves as the clear key and a double beep will be heard when this key is pressed. A "*GOODBEEP*" is represented by an oscillating high tone. An "*ERROR BEEP*" is represented by a single low tone.

THE RED & YELLOW LED's

Two different colored LED's are in the face of the unit. The red LED will light during the duration of the relay(s) activation period. The yellow LED will light while the unit is in the program mode. During memory erasure or setup the LED's will flash.

RESETTING THE UNIT

Your unit provides 2 different types of resets, a Unit Reset, and a Master Reset.

A Master Reset should be utilized in the event that you lose or forget your master code or if the unit is in the Latch or Sleep mode and the Latch or Sleep code is lost or forgotten. When a Unit Reset is performed, the master code will be set back to 1 2 5 1.

A Unit Reset is provided should it ever become desirable to reset the unit back to the initial factory state. After a Master Reset has been performed the unit will *DELETE ALL ACCESS & FUNCTION CODES* and the master code will be set back to 1 2 5 1.

MASTER RESET

Follow these steps precisely. If you make an error, the unit will *ERROR* and you will have to start over.

Disconnect power from the unit by pulling the wire harness away from the board. Reconnect power to the board while holding down the *RESET* button (See location diagram, pg. 11).

Release Reset button and enter * * * from the keypad.

The unit will issue a good beep and the master code will be set back to 1 2 5 1. If you previously were in the sleep or latch mode, the unit will be brought back to idle state.

UNIT RESET

(!!!! WARNING: ALL CODES WILL BE DELETED FROM MEMORY !!!!)

* (Please See pg. 6 for further information)

Follow these steps precisely. If you make an error, the unit will *ERROR* and you will have to start over.

Disconnect power from the unit by pulling the wire harness away from the board. Reconnect power to the board while holding down the *RESET* button (See location diagram, pg. 11).

Release Reset button & enter **# * #** (The unit will respond with a *GOOD BEEP*)

Enter the *MASTER CODE* from the keypad. (The unit will flash the *LED's* several times and then go into an endless cycle of beeps)

Disconnect & Reconnect power to the unit. (The unit will go through the "First Time Power Up" sequence (See page 5).

The idle mode

The idle mode is the normal mode of operation. When in this mode the unit sits and waits for data from the keypad. When in this mode you will have approximately 4 seconds between keypresses. If this time is exceeded, you will receive an *ERROR*.

The program mode

The program mode is the mode of operation in which you will enter, delete, or change your codes or set specific features of the unit. The program mode is accessed by entering the "*MASTER CODE*" from the keypad. You will receive a *GOOD BEEP* and the yellow *LED* will come on indicating that you are in the program mode. In this mode you will have approximately 30 seconds between key presses. If this time is exceeded, you will receive an *ERROR* and be exited from the program mode.

The * and # keys

The * and # keys serve specific functions while in the idle or program mode. The * key is always the clear key and a double beep will be heard when depressed. You should use this key if you make an entry error. The # key also serves as the clear key in the idle mode. In the program mode however, it

serves as the exit key and will at any time when depressed, exit you from the program mode.

PROGRAMMING

A person desiring access to the program mode will enter the present *MASTER CODE*. If the master code is valid the yellow *LED* will come on and the individual will be prompted with a *GOOD BEEP* to enter a number corresponding to a *SUB-MODE*.

Remember: Master Code will not activate control relay.

(*MASTER CODE*) + (Number corresponding to Sub-Mode).

Once in the program mode, the individual will have 30 seconds between keypresses or the unit will *ERROR* and exit the program mode. A person desiring to exit the program mode may do so by simply pressing the **#** key at any time. There are 10 different *SUB-MODES* to choose from. They are as follows:
SUB-MODE DESCRIPTION

1	Program Access Codes (Relay A)
2	Delete Codes
3	Change Master Code
4	Set Sleep Code and/or Latch Code
5	Set One Shot Code
6	Set Relay Output Times
7	Program Access Codes (Relay B)
8	Enable / Disable "3 Strikes-You're Out"
9	Program Event Input
0	Erase Memory

Sub-Mode 1 (Program Relay A Access Codes)

To program new Relay A access codes enter the following;

(*MASTER CODE*) + 1 + (*NEW CODE*) + (*NEXT NEW CODE*)
etc..... (**#** to exit)

Should you make a code entry error, simply press the ***** key and enter the correct code. You may select any 4 digit code you wish. If you receive an *ERROR* after entry, you must select another code as it is already in use. The unit will respond with a *GOOD BEEP* with the acceptance of each new Relay A code. You may continue entering Relay A codes until you finish (Press **#**), or the memory becomes full. You will automatically be exited from the program mode if the memory reaches capacity. When memory is full you will not be able to enter this Sub-Mode and will receive an *ERROR* if entry is attempted.

Sub-Mode 2 (Delete Codes)

To delete codes enter the following;

(MASTER CODE) + 2 + (CODE TO BE DELETED)

Should you make an entry error, simply press the * key and enter the correct code. You may delete any access or function code that you wish with the exception of the *MASTER CODE*. If the code you wish to delete is not found in memory, the unit will respond with an *ERROR* and wait for another code to be entered. A *GOOD BEEP* will be sounded once the code has been found and deleted. You may continue deleting codes until you finish (Press #).

Sub-Mode 3 (Change Master Code)

To change your master code enter the following;

(present MASTER CODE) + 3 + (new MASTER CODE)

Should you make a code entry error, simply press the * key and enter the correct code. You may select any 4 digit master code you wish. If you receive an *ERROR*, you must select another code as it is already in use. The unit will respond with a *GOOD BEEP* with the acceptance of the new Master Code and you will be exited from the program mode. *MAKE SURE TO WRITE THE NEW MASTER CODE DOWN.*

Sub-Mode 4 (Set Sleep Code and/or Latch Code)

EXPLANATION: The sleep code used to disable all Relay A and function codes from the keypad. It also turns shuts off the *CALL* button on the intercom. This feature is most commonly used in applications where no entry is desired after hours. Relay B codes will still be valid from the keypad. By connecting both relays in parallel, managers may be assigned RelayB codes and still gain access. While in the *SLEEP MODE*, the yellow and red *LED's* will flash approximately once every 3 seconds. To initialize the system back to normal, simply re-enter the sleep code. Should you lose or forget your sleep code and the unit is in the sleep mode see the Unit Reset instructions on page 15.

NOTE: You can also toggle the sleep code with the telephone. (See intercom operating instructions.)

To program or change your sleep code enter the following;

(MASTER CODE) + 4 + 1 + SLEEP CODE

Should you make a code entry error, simply press the * key and enter the correct code. You may select any 4 digit sleep code you wish. If you receive an *ERROR*, you must select another code as it is already in use. The unit will

respond with a *GOOD BEEP* with the acceptance of the new Sleep Code and you will be exited from the program mode.

(Set Latch Code)

EXPLANATION: The Latch Code toggles the state of the main relay (A) of the circuit board. The red LED will light if the relay is in the latched position. The latch code is useful in applications where the gate is desired to hold open. If the operator's close circuit is controlled by loops, timers, etc., they will be overridden by the latched state of the relay and the gate will hold open. An "OPEN - OVERRIDE" circuit must exist in the operator in order to utilize this function. If your gate cycles when this code is entered, your operator is not set up to utilize this function. Your local dealer or distributor should be able to assist you if you have any specific questions.

To program or change your latch code enter the following;

(MASTER CODE) + 4 + 2 + LATCH CODE

Should you make a code entry error, simply press the * key and enter the correct code. You may select any 4 digit latch code you wish. If you receive an ERROR, you must select another code as it is already in use. The unit will respond with a GOOD BEEP with the acceptance of the new Latch Code and you will be exited from the program mode. When the latch code is entered the RED Led will light and the gate will hold open. When the latch code is entered again the RED Led will go off and the gate will close. NOTE: On gates with a timer to close the "TIMED DURATION" starts when the latch code is released.

Sub-Mode 5 (Set One Shot Code)

EXPLANATION: This Mode is used to program a one-shot code, and to enable it or disable it. After the ONE-SHOT CODE is programmed in you must enable it after each use. **NOTE: The ONE-SHOT CODE must be programmed first.** After the 5 is pressed the enable/disable status is heard (one beep = enabled, two beeps = disabled) followed by a GOOD BEEP.

To program or change the one-shot code enter:

(MASTER CODE) + 5 (*status) + 2 + (ONE-SHOT CODE)

To disable the one-shot code enter:

(MASTER CODE) + 5 (*status) + 0

To enable the one-shot code enter:

(MASTER CODE) + 5 (*status) + 1

To change the one-shot code enter:

(MASTER CODE) + 5 (*status) + 2 + (ONE-SHOT CODE)

To change the relay the one-shot code activates enter:

(MASTER CODE) + 5 (*status) + 3 + (RELAY #)

The Relay # corresponds to which relay to set. 1 = Relay A, 2 = Relay B.

Sub-Mode 6 (Set Relay Output Times)

To set or change a relay output time enter the following;

(MASTER CODE) + 6 + (RELAY #) + (RELAY OUTPUT TIME) in seconds

The Relay # corresponds to which relay to set. 1 = Relay A, 2 = Relay B. Should you make a code entry error, simply press the * key and enter the correct code. Your output time is set on both relays from the factory at approximately 1/2 seconds "00". If a longer output time is desired, enter a two digit number corresponding to the number of seconds between "00" and "99". By entering "00" the output time is set to approximately 1/2 seconds which is ideal for most operators.

Sub-Mode 7 (Program Relay B Access Codes)

To program new Relay B access codes enter the following;

(MASTER CODE) + 7 + (NEW CODE) + (NEXT NEW CODE)
etc..... (# to exit)

Should you make a code entry error, simply press the * key and enter the correct code. You may select any 4 digit code you wish. If you receive an *ERROR* after entry, you must select another code as it is already in use. The unit will respond with a *GOOD BEEP* with the acceptance of each new Relay B code. You may continue entering Relay B codes until you finish (Press #), or the memory becomes full. You will automatically be exited from the program mode if the memory reaches capacity. When memory is full you will not be able to enter this Sub-Mode and will receive an *ERROR* if entry is attempted.

Sub-Mode 8 (Enable/Disable 3 Strikes-You're Out)

EXPLANATION: This feature is desirable to keep unwanted persons from successively entering codes until they "hit" a programmed access code. By selecting this function you enable a 1 1/2 minute lock out period if 3 incorrect codes are entered successively within a 3 minute period. When this occurs, the *LED's* will flash and a high pitched alarm will be generated from the unit for 30 seconds. The unit will then shutdown for 1 minute.

To toggle the 3 strikes-you're out feature enter the following;

(MASTER CODE) + 8 (*current state) + (MASTER CODE)

*current state

single beep = 3 strikes enabled

double beep = 3 strikes disabled

Should you make a code entry error, simply press the * key and enter the correct code. After you have selected mode 8, the unit will respond with a single or double beep. A single beep indicates that the 3 strikes-you're out feature is presently enabled. A double beep indicates that the 3 strikes-you're out feature is presently disabled. The unit will then issue a *GOOD BEEP* and wait for the master code. If you wish to toggle the 3 strikes your out state, enter the master code. If you do not wish to toggle the state, enter # to exit.

Sub-Mode 9 (Program Event Input)

EXPLANATION: The event input allows the user to tie in an external device to control specific functions of the unit. The event input can be programmed in 1 of 5 ways.

REMOTE INACTIVE: Relay A codes may be made inactive by an external switch. When inactive all relay A codes will be disabled. The relay B, program, and function codes will still be accessible to the end user.

ARMING CIRCUIT: This is normally used to allow access in parking situations. An external vehicle detector may be connected to the input. Relay A codes would only become active on the presence detect of a vehicle. If an entry attempt to activate relay A is made while the input is not activate, entry will be denied. The relay B, program, and function codes will still be accessible to the end user.

REMOTE OPEN: A relay may be activated using a pushbutton or switch. The relay to activate is user selectable. This function operates even when the unit is in sleep, latch, or program mode.

NIGHT LIGHT: This will turn on the unit night light for 60 seconds using a relay connected to a loop detector, electric eye, motion sensor, etc. You must move the Lights jumper from On to Event to use this output. See circuit board layout on page 7 for location.

DISABLE: Disables the Event Input.

To program the event input as Remote Inactive enter the following;

(MASTER CODE) + 9 (*current mode) + 1

To program the event input as an Arming Circuit enter the following;

(MASTER CODE) + 9 (*current mode) + 2

To program the event input as Remote Open enter the following;

(MASTER CODE) + 9 (*current mode) + 3 + (*Relay to Activate)

To program the event input as NIGHT LIGHT enter the following;

(MASTER CODE) + 9 (*current mode) + 4

To DISABLE the event input enter the following;

(MASTER CODE) + 9 (*current mode) + 0

*Current Mode	*Relay to Activate
Single beep = Remote Inactive Mode Enabled.	1 = Relay A.
Double beep = Arming Circuit Mode Enabled.	2 = Relay B.
Triple beep = Remote Open Mode Enabled.	
GoodBeep Only = Event Input Disabled.	

After you have selected mode 9, the unit will respond with tones as described above. This gives the current mode the event input is programmed as (See *Current Mode above). If you do not wish to toggle the state, enter **#** to exit. If you are programming the event input as a Remote Open input, you will be prompted for which relay to activate on an event. Enter the correct relay as stated above (*Relay to Activate).

Sub-Mode 0 (Erase all codes)

To erase all access & function codes, (except the master code), enter the following;

(MASTER CODE) + 0 + (MASTER CODE)

Should you make a code entry error, simply press the * key and enter the correct code. When the sequence is entered correctly, the *LED's* will flash several times and the unit will generate a *GOOD BEEP* when it has finished clearing the memory. If the above sequence is not validated by the unit you will receive an *ERROR* and immediately be exited from the program mode.

AN IMPORTANT NOTE: It should not generally be necessary to erase all the codes from memory unless codes are forgotten and are occupying necessary memory. A good log and maintenance of access codes should prevent this from ever needing to be done.

Support

Customer Service: (303) 799-9757

Customer service is available free of charge. Hours are 8:00 a.m. to 5:00 p.m. MST. If you call, please have your Model and Serial # to help our technicians assist you with any problems you have.

E-Mail: customerservice@americanaccess.com

Technical Support: (303) 799-9757

Technical support is available free of charge. Hours are 8:00 a.m. to 5:00 p.m. MST. If you call, please have your Model and Serial # to help our technicians assist you with any problems you have.

E-Mail: techsupport@americanaccess.com