



Information Manual

Loops and Loop Detectors

DoorKing, Inc.
120 Glasgow Avenue
Inglewood, California 90301
U.S.A.
Phone: 310-645-0023
Fax: 310-641-1586
www.doorking.com

Table of Contents

- INTRODUCTION
 - The Underground Loop 5
 - The Lead-In Cable 5
 - The Loop Detector 5
 - Design Facts 6

- HOW THE LOOP SYSTEM WORKS
 - Field of Sensitivity 9
 - Height of Detection 9
 - Loop Phasing 10
 - Field Cancellation Effect 10
 - Field Enhancement Effect 11
 - Phasing Loops 11

- LOOP INSTALLATION GUIDELINES
 - Saw Cut Guidelines 13
 - Preformed Loop Guidelines 14

- TYPICAL LOOP LAYOUTS
 - Slide Gates 15
 - Swing Gates 16

- TROUBLE SHOOTING LOOP SYSTEMS
 - Loop Diagnostics 17
 - Poor Connections 17
 - Shorted Loop Wire 17
 - Detector Adjustments 17

- DOORKING LOOP DETECTORS AND ACCESSORIES 18

INTRODUCTION

A loop detection system is a method of sensing vehicles and is typically used in automated gate applications to prevent a gate from automatically closing on a vehicle or to automatically open the gate when a vehicle is exiting a property. Vehicle loops can also be used to activate card readers, ticket spitters, etc. When properly installed, loops are an extremely reliable form of vehicle detection. The loop detection system operates by creating a field of sensitivity that tunes to the surrounding environment. When a metallic object enters this field, the loop detector senses a change in the field and generates an output, usually in the form of a relay closure, which can then be used to control a gate operator or other devices. There are three basic components in a loop detection system: the underground loop, the lead-in cable, and the loop detector.

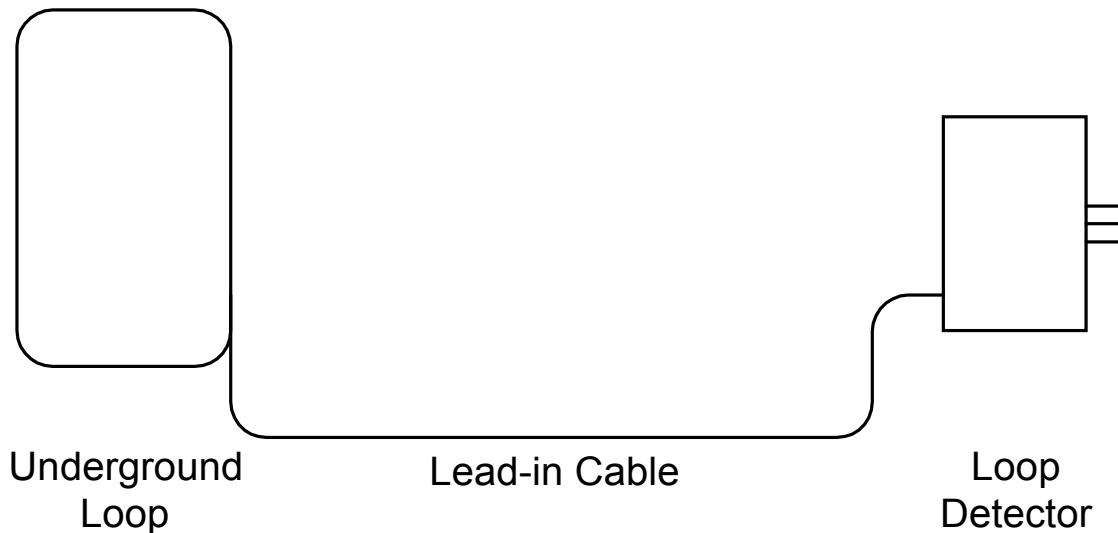

The Underground Loop

The loop is made from a continuous piece of wire (NO SPLICES) that is coiled around for a number of turns in a square or rectangular pattern. The wire is embedded into pavement either as a preformed loop placed prior to paving, or into a saw cut that is cut into existing pavement. Both ends of this wire are then extended to the edge of the pavement.

The Lead-In Cable

The lead-in cable extends the two ends of the loop wire back to the loop detector. On short runs (ten feet or less), the two wires exiting the loop can be twisted together and connected directly to the loop detector. This wire must be twisted a minimum of five turns per foot. For runs longer than ten feet, you may want to splice on a separate lead-in cable to simplify installation. The lead-in cable must be a twisted pair, shielded cable with a direct burial rated jacket or be placed in conduit. All splices must be soldered and placed in a watertight J-box.

The Loop Detector

The loop detector is the electronic component that controls the loop system. DoorKing offers loop detectors (Models 9405, 9406) that plug directly into the gate operator control board, eliminating the wire harness and wiring connections other than the loop lead-in wires. These detector boards have a terminal strip where the loop lead-in wire connects. There are also various other types of standalone detectors available on the market that can be hard wired into the gate operator control board.

Design Facts – Read Carefully!

Proper installation of the loops is essential for reliable functioning of the detector system. Most detector problems are caused by improper loop installation! **The geometry (size and shape) of the loop defines the detection zone characteristics.**

- Loop size may vary and will depend on lane width, traffic patterns, and types of vehicles to be detected.
- **Small loops (6 feet x 8 feet) are used to detect motorcycles and automobiles. Minimum size for loops to detect typical vehicular traffic is 4 feet x 6 feet. It is always recommended to use a larger loop whenever possible.**
- Large rectangular loops (8 feet x 20 feet) are used to detect large, high bed vehicles such as trucks.
- **The short leg of any loop used for vehicle detection should never be less than 4-feet.** The height of detection is directly related to the length of the short leg of the loop. A general rule of thumb to follow is that the height of detection is 2/3 the length of the short leg of the loop.
- Loops can be saw cut into concrete or asphalt, and can be placed under a preformed road surface, such as concrete and brick pavers.

Physically adjacent loops operating on separate detector modules may interfere (cross talk) with each other. Changing the operating frequency on one of the loop detectors can eliminate this interference.

The detector must operate from stable AC power. If the detector is subjected to excessive line voltage variations, the detector may cause either false outputs or may drop an output when a vehicle is over the loop. For example, if a gate operator is located some distance from the power distribution panel and the feeder wires are undersized, the inrush current when the motor starts will cause a momentary drop in the line voltage. If this voltage drop is more than 25% of the nominal line voltage, the loop detector will see this as a power failure and will reset when the voltage returns to the nominal level. If a vehicle is over a loop when the detector resets itself, the detector will no longer sense the vehicle presence.

When connecting more than one loop to a detector, always connect the loops in series. If the loops are close together, the direction of the windings should be considered. Loops physically near each other and wound in the same direction electrically (i.e. both CW or CCW) will cause field cancellation effects (a dead zone) between the loops. This may be desirable when two loops (reverse loops) are placed on each side of a sliding gate. Wiring the loops in this manner will allow the gate to slide between the two loops without causing the loops to detect the gate. If the loops are wound in electrically opposite directions (i.e. one CW and one CCW), field enhancement will occur between the loops, effectively extending the field of sensitivity for the loop system.

Use the table below to determine the number of turns required for a single loop installation. Loop area (Sq. Ft.) is determined by multiplying loop width by loop length.

Loop Area (Sq. Ft.)	Turns
6 – 12	6
12 – 60	4
60 - 240	3

- During the construction of new installations (i.e. concrete or asphalt), a pre-formed loop may be used as an alternate to the saw cut type. Pre-formed loops are typically encased in PVC or other durable materials to provide high reliability and long life. Sizes may vary depending on the source of the pre-formed loop. DoorKing offers a variety of pre-formed loops that come with 25 feet of lead-in wire.
- The loop will tune to its environment. Stationary or static metal objects, such as conduits, pipes, metal grates, etc., will not affect the loop field. High voltage electrical power lines, either underground or overhead, can affect the loop field. In addition, fluctuating electrical fields, such as heating coils, can cause loop lock-ups and false detection.
- A heavy grid of reinforcing bars (re-bar) may affect the loop field. To minimize this, do not place a loop directly on the rebar. Support the loop 1 - 2 inches above the rebar. If possible, make cuts or bends in the rebar grid directly below the loop. Bars and electrical wires running at angles to the loop have less effect on the loop than those running parallel to the loop wires.
- If a single loop is used with a long lead-in cable (500 feet or greater), it is advisable to add an additional turn in the loop. This increases the ratio of the loop inductance to the total inductance, thereby improving loop sensitivity and overall loop system stability.
- The inductance of the loop (in micro henries) must fall within the tuning range of the loop detector for the loop system to operate properly. This is typically not a problem since most loop detectors have a very wide tuning range (20 - 2500 micro henries) and can accommodate most size loops. To calculate the inductance of a loop, use the formula below.

$$\text{Inductance} = \frac{(S1+S2+S3+S4)T^2}{2}$$

For example, to calculate the inductance of a typical 6 x 8 foot loop with four turns of wire:

$$\frac{(6+8+6+8)4^2}{2} = 224 \text{ Micro Henries}$$

HOW THE LOOP SYSTEM WORKS

Field of Sensitivity

A loop sets up an inductive field, called a field of sensitivity. **This field of sensitivity completely surrounds the loop wires extending above, below, and on all sides of the loop.** When a vehicle (or any metallic object) enters this field of sensitivity, the inductance of the loop changes as more of the inductive field is disrupted by the vehicle. Once the disruption of the inductive field is high enough, the loop detector senses this change and outputs a signal, usually in the form of a dry contact relay closure.

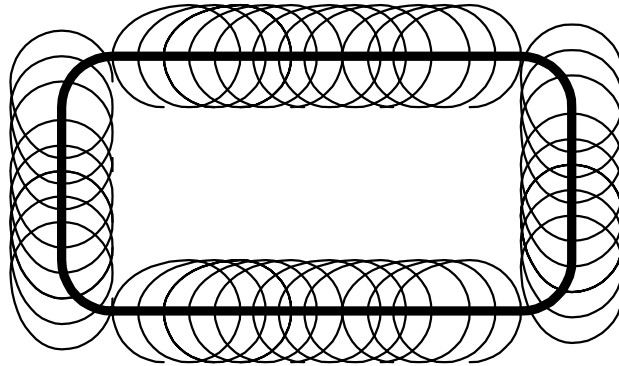

Height of Detection

The height of the field of sensitivity, and therefore the height of detection, is determined by the size of the loop. The height of detection is especially important when you need to detect a high bed truck, which requires more height than a passenger car. The height of detection above (and below) the loop is determined by the shortest leg of the loop. The height of detection is equal to $1/2$ to $2/3$ the length of the short leg. For example, a four-foot by eight-foot loop will give you approximately 2-1/2 feet of detection height, whereas a six-foot by eight-foot loop will give you approximately 4-feet of detection height. The short leg of a loop used for vehicle detection should never be shorter than 4-feet.

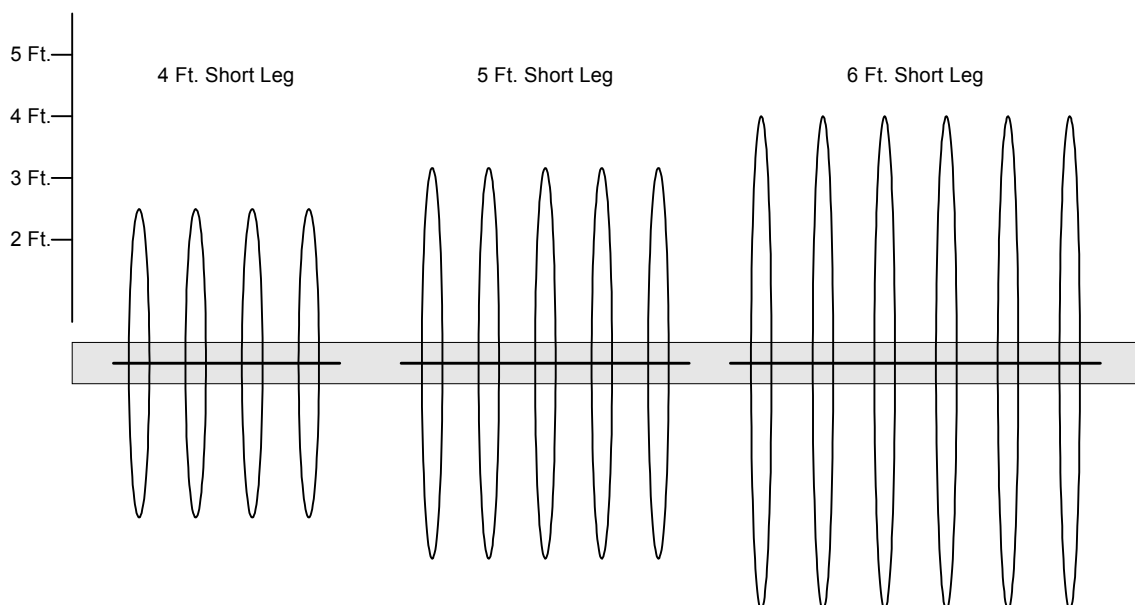

Loop Phasing

It was mentioned previously that when two loops are used with the same detector, they must be connected in series and the direction in which each loop is wound is important for proper door or gate operation. It is also advisable to have the loop connections accessible for maintenance and repair. That is to say, route the lead-in cable of both loops to the loop detector, where the connections can be made to wire the loops in series.

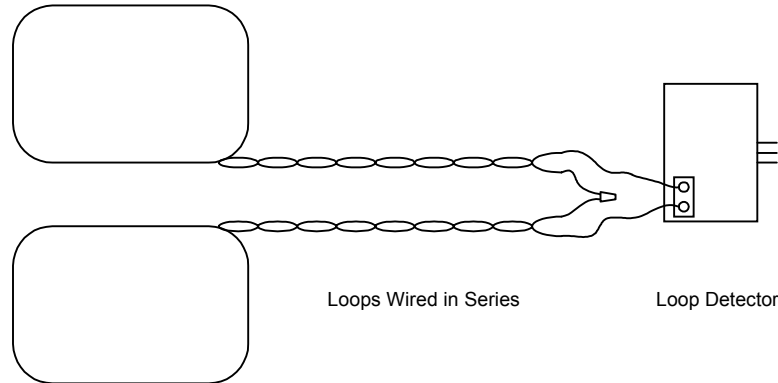

In many gate applications, two loops are wired in series to provide a reversing loop function on each side of the gate. It is especially important when two reverse loops are wired in series in slide gate applications that loop phasing be observed so that a dead zone is created between the loops. This will allow the slide gate to pass between these loops without causing the loop system to detect the gate.

Field Cancellation Effect

Winding the loops in the same direction (CW or CCW) electrically creates the effect of the electrical current passing through the closest edges of the loops in opposite directions. Since the electrical currents are flowing in the opposite directions, the inductive fields of sensitivity created have the same magnetic poles (North or South) toward each other. Since "likes" repel, the fields of sensitivity are pushed up and away from each other, creating a dead zone.

- The detection envelope shown is a relative profile of the detection height and will vary with the size of the loops, spacing between the loops, and the type of vehicle. The relative height over the two inside wires increases as the loops are moved closer together and decreases as the loops are moved apart.

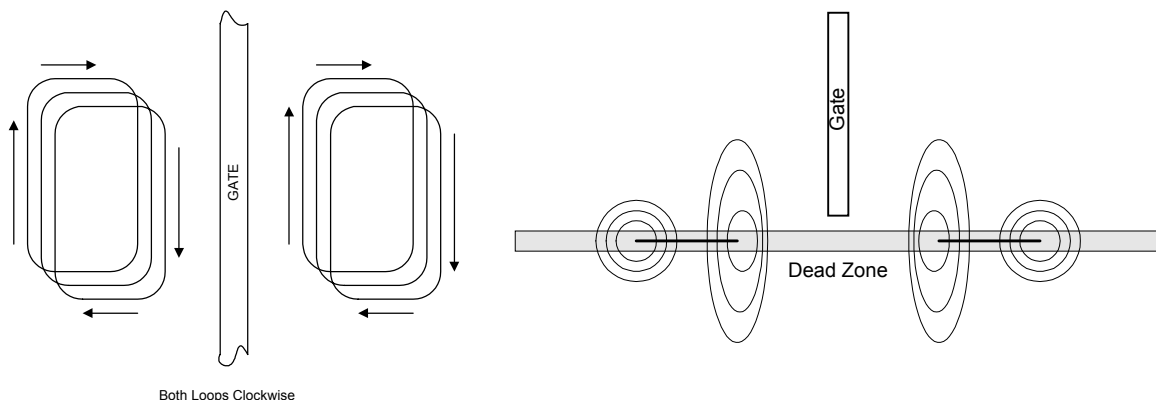

Field Enhancement Effect

Winding the loops in the opposite direction (CW and CCW) electrically creates the effect of the electrical current passing through the closest edges of the loops in the same direction. Since the electrical currents are flowing in the same direction, the inductive fields of sensitivity created have opposite magnetic poles (North or South) toward each other. Since "unlikes" attract, the fields of sensitivity pull towards each other, creating a larger zone of detection. Winding the loops in electrically opposite directions could create an enhanced zone that would inhibit a slide gate from closing.

The detection envelope shown is a relative profile of the detection height and will vary with the size of the loops, spacing between the loops, and the type of vehicle. The relative height over the two inside wires decreases as the loops are moved closer together and increases as the loops are moved apart.

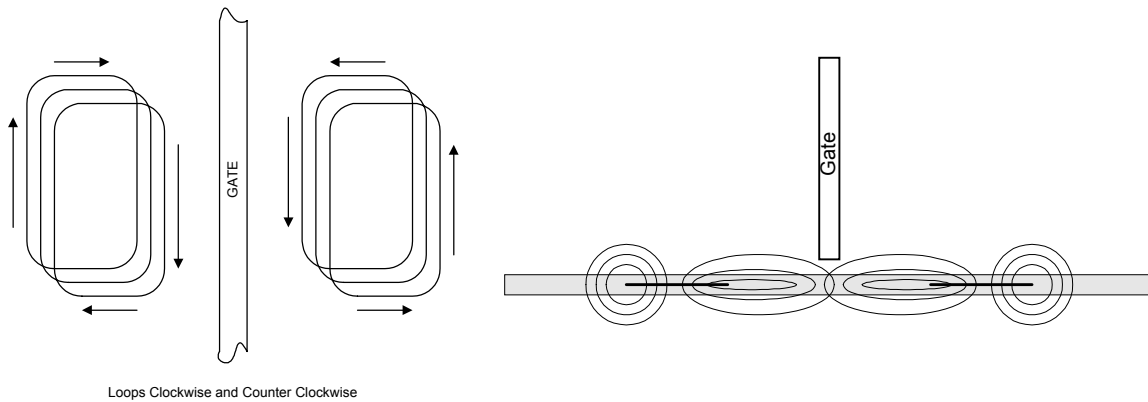

Phasing Loops

Phasing loops refers to the direction that the electrical current flows through the loops, and not necessarily the physical direction that the loop wire has been wound. For example, if two loops are installed and physically wound in a CW direction, you can reverse the electrical current through one of the loops by simply reversing the connection where the loops are wired together. Doing this effectively changes the "electrical" direction that the loops are wound.

LOOP INSTALLATION GUIDELINES

In order to have a loop detection system operate as a reliable, high performance system, it is necessary to pay careful attention to the loop installation. The use of proper installation techniques and the proper type of wire can reduce frustration, aggravation, and unnecessary service calls.

Saw Cut Guidelines

- After determining the size and placement of the loop, use a concrete saw to cut a slot into the pavement. The saw slots must be of the proper depth (1 1/2 to 3 inches), clean, and with no sharp corners that can damage wire insulation during installation. The greater depth should be used in softer pavement materials to protect the loop installation against damage from surface erosion and wear. The width of the saw cut should be wide enough to allow easy installation of the loop wire. DoorKing loop wire has a .120" (+/- .003") diameter, which will allow it to fit into a slot cut with a 1/8-inch blade.
- The type of wire used in the loop can significantly affect the reliability and life expectancy of the loop. A wire with an insulation rated for direct underground burial must be used. Since moisture can cause significant changes in the dielectric constant of the insulation, which results in excessive loop (frequency) drift, choose an insulation that is impervious to moisture. **Polyvinyl Chloride (PVC) insulation (TFFN, THHN, THWN) should be avoided since it tends to absorb moisture. This type of wire is designed for power distribution and is not designed for direct underground burial. Cross Linked Polyethylene (XLPE) insulated wire is very resistant to moisture absorption and provides good abrasion resistance.** DoorKing loop wire meets these requirements (see selection chart on page 17). Remember, the loop must be wound with one continuous length of wire - NO SPLICES ARE ALLOWED!
- The wire must be held tightly in the bottom of the slot by means of a plastic foam type material called "backer rod." Backer rod should be used on the entire perimeter of the loop as well as where the wire exits the loop. The backer rod forms a barrier between the wire and the sealant, which allows the wire to shift with any pavement shiftment. Loose wires can cause false calls when subjected to vibration or sudden movement. If the wire is completely covered, it is very important that no void exist, which could allow water to collect. The water will expand during freezing conditions. The freeze/thaw cycle will push the wire up and out of the slot causing a loop failure.
- Choose a sealant to match the application of the pavement. Hard setting epoxies should not be used in asphalt.

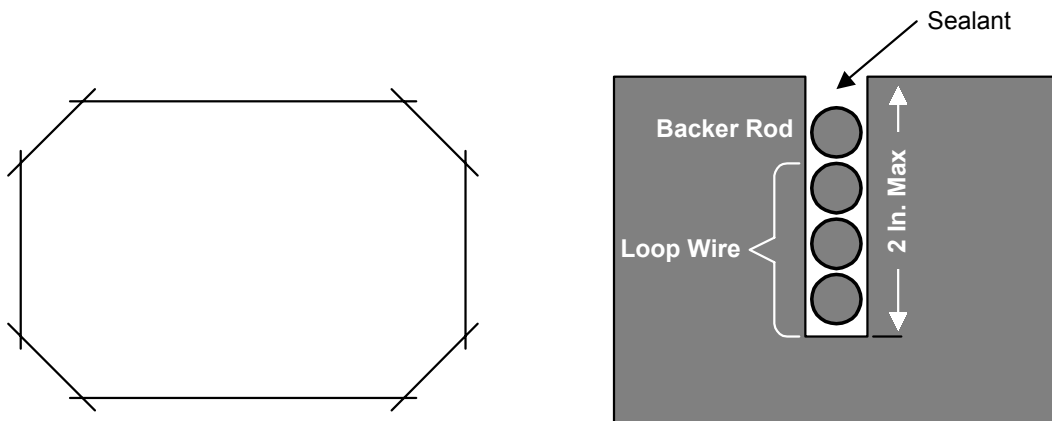

Saw Cut Guidelines (Cont)

- Where the loop wires leave the saw cut, they must be tightly twisted with a minimum of five turns per foot. Use tape on the twisted end to hold the wires together. This prevents false calls from movement between the wires.
- A lead-in cable should be used if the distance between the saw cut and the detector exceeds ten feet. The lead-in cable should be a shielded, twisted pair with a high-density polyethylene insulation. The shield should be floated (left unconnected and insulated) at the splice end and should be grounded to earth ground at the cabinet end only. Any other grounding arrangements can cause erratic system operation.
- All splices must be soldered -- do not use any wire nuts. The output from the loop detector to the loop is at very low voltage. This means that there is not enough power to go through a bad connection. Each splice point must be protected with a moisture proof seal. No splices are allowed in the loop itself.

Preformed Loop Guidelines

- The same careful attention to proper installation guidelines described for saw cut loops also apply to the installation of pre-formed loops.
- Pre-formed loops should be installed 2 to 3 inches below the surface of the pavement.
- If installed in asphalt, cover the loop with 1-inch minimum of soil or sand to protect the loop from hot asphalt.
- Wire mesh or reinforcement in concrete should be cut away a minimum of 6 inches from the perimeter of the loop.

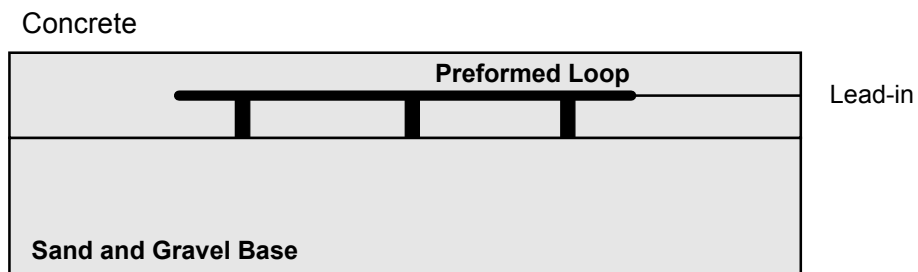
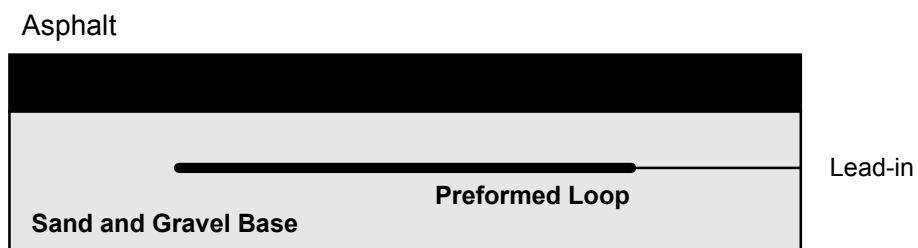

TYPICAL LOOP LAYOUTS

Slide Gates

Slide gates require the use of two reversing loops wired in series to a single detector for maximum vehicular protection. Be sure that the two reverse loops are properly phased so that the gate can slide through the "dead zone." The optional open loop requires a second loop detector.

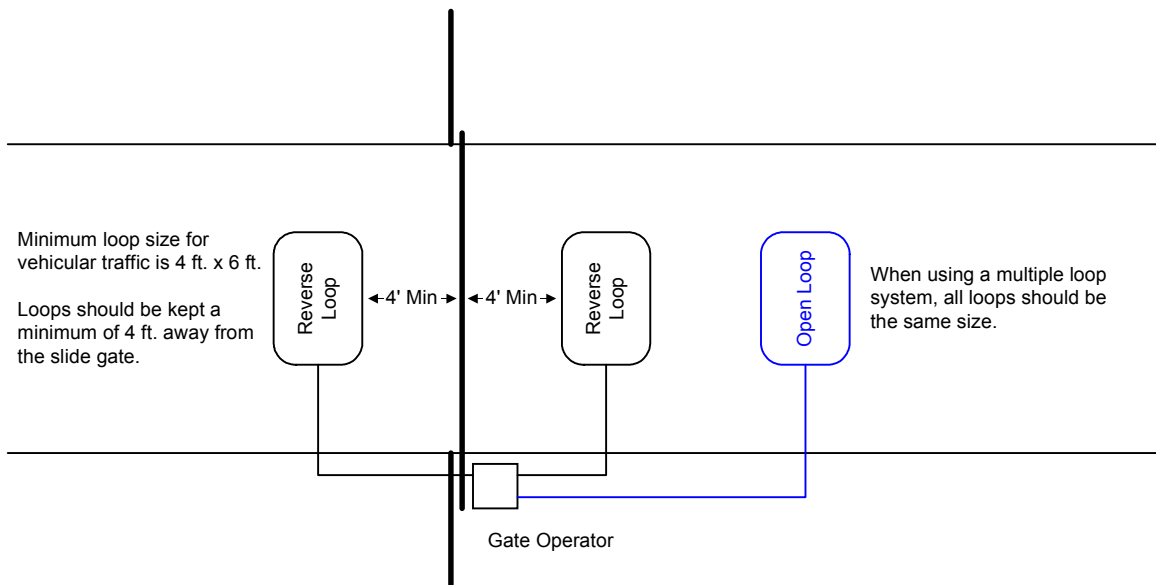
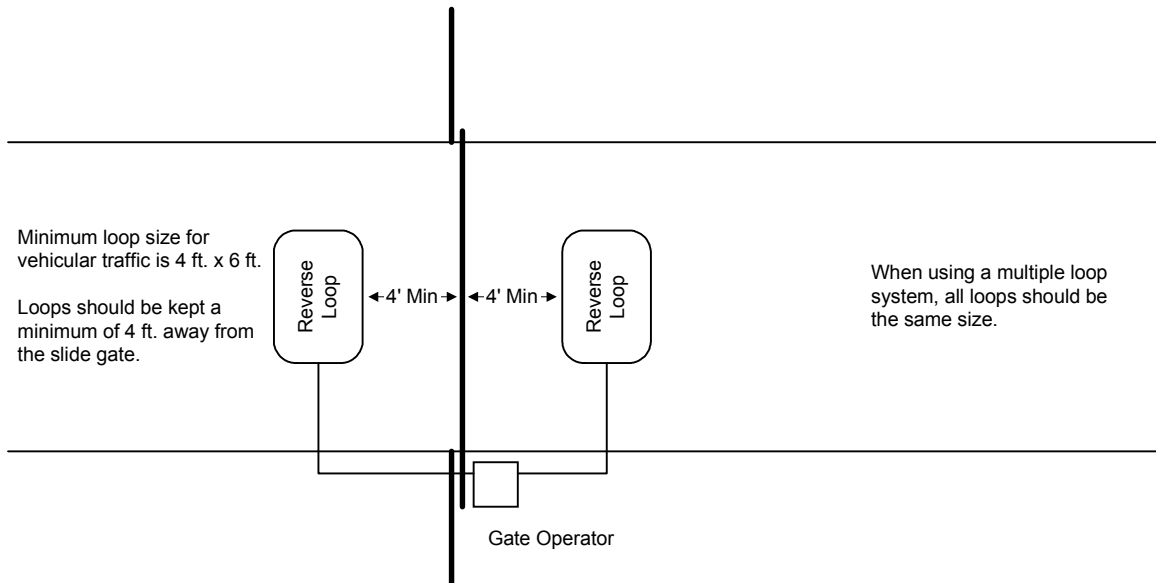

Swing Gates

Swing gates typically use two reverse loops that are installed out from the path of the gate. This is necessary so that the loops do not detect the swing gate swinging over a reverse loop, which would cause the gate to reverse. However, this leaves a large unprotected area as shown below.

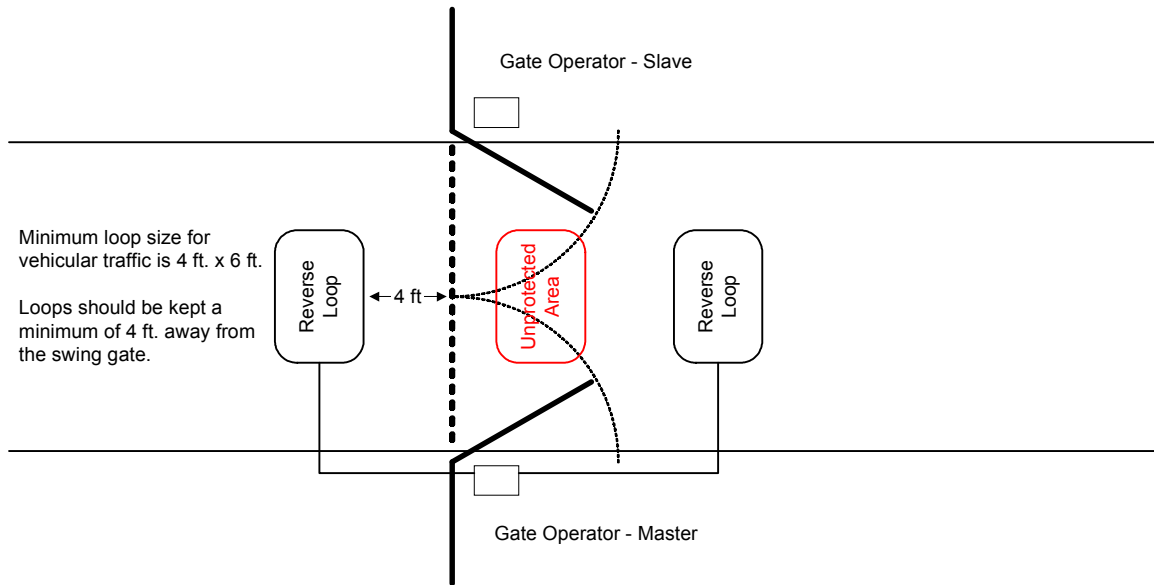

To eliminate the unprotected area, a "shadow" loop is installed under the path of the gate. The control circuit in the gate operator will only accept inputs from the shadow loop detector when the gate is in the full open position. Once the gate begins its closing cycle, the gate operator ignores any input from the shadow loop detector, thereby allowing the gate to pass over the shadow loop without reversing itself. The reverse loops and shadow loop require a two-channel loop detector. The optional open loop requires a single loop detector.

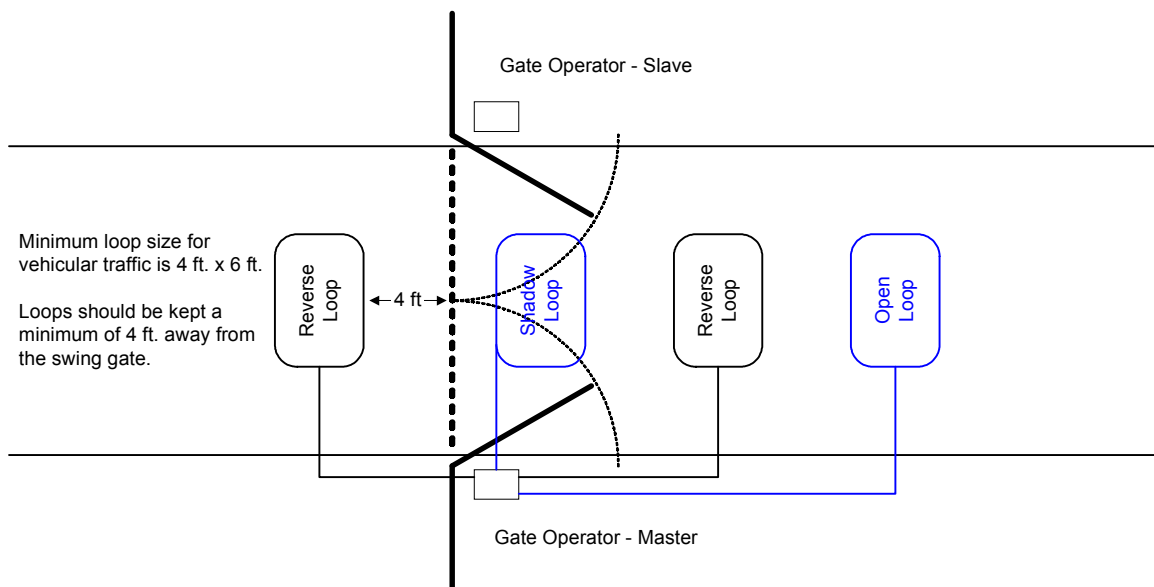

TROUBLESHOOTING LOOP SYSTEMS

Proper installation of the loops is essential for reliable functioning of the detector system. Loop detection systems, when properly installed, will provide one of the most reliable forms of vehicle detection available. Many loop system problems are caused by poor connections, splices, incorrect type of loop wire, or the loop wire shorting to ground all of which will cause intermittent operation or complete failure.

Loop Diagnostics

DoorKing loop detectors have a provision that provides loop diagnostics, which identifies if a problem has occurred in the detection system. The red LED on the loop detector will illuminate when the detector senses a vehicle presence, and will go out when the vehicle leaves the field of sensitivity. If any problem occurs in the underground loop, lead-in cable, or in any of the connections, this LED will go into a fault mode by flashing three quick blinks, pausing, then flashing three quick blinks, etc. If the problem is a short or an intermittent poor connection, which corrects itself, the detector will return to normal operation, however the LED will continue to blink in the fault mode until it is manually reset or until power is removed from the system. If the LED is blinking, even if the detector is working properly, a problem exists and checks should be made for poor connections or shorts to ground.

Poor Connections

A poor connection from the loop to the loop detector will generally cause an intermittent problem where the loop will "false call" or "lock on." Often a crimp connection, wire nut, or similar type connector will operate when they are originally installed, but after a period of time the wires may corrode, or the connection will loosen. Vibrations from gate operators can cause these loose connections to be intermittent and generate false calls, or lock up the detector. Remember, the power through the loop is very low and does not have enough power (like 110 volt connection) to go through any type of corrosion or loose connection. Be sure that all connections are soldered.

Shorted Loop Wire

The loop wire shorting to ground is a very common problem. This is especially true when a poor grade of wire (THHN, TFFN, etc.) is used for the ground loop or a splice was made underground. These types of problems will often cause problems when moisture is present. If there is a nick in the wire insulation, the loop will work when the ground is dry, but moisture is present (rain, sprinklers, morning dew, etc.) the nick causes a short to ground. This can be checked by utilizing a megohm meter capable of testing up to 500 megohms (500 million ohms), such as a DoorKing meter P/N 9401-045. Disconnect the loop wires from the loop detector. Place one of the meter leads to the loop wire and the other to earth ground. Resistance should be greater than 100 megohms. If resistance is between 100 and 50 megohms, the wire insulation has been nicked and the integrity of the loop is questionable. If the resistance is less than 50 megohms, the loop wire will have to be replaced.

Detector Adjustments

- Sensitivity sets how much metal must be present for the detector to send an output.
- Sensitivity Boost increases sensitivity by a factor of ten once a vehicle is detected. This locks in high bed trucks. Turning the boost on when the sensitivity is set at high may cause loop lock-up.
- Frequency sets the operating frequency of the loop. When two loops are operating in close proximity to each other, the frequency on each detector should be set differently. The loop with the longest length of wire should be set at the lowest frequency.
- Frequency Counter - LED blinks out frequency.

DOORKING LOOP DETECTORS AND ACCESSORIES

All loop detectors have the following features:

- Self-tuning circuitry. Automatically adjust for different loops and changes in weather.
- Sensitivity boost automatically increases sensitivity during detection. Prevents dropout from high bed vehicles.
- Four frequencies available.
- Four sensitivity levels available.
- LED's to indicate when power is applied to the detector and when the loop is triggered.

Part Number	Description
9406-010	Single channel plug-in detector board. Four different sensitivity and frequency settings. Sensitivity Boost feature, frequency counter, and Fast Trak feature. Manufactured by DoorKing Inc.
9405-010	Two channel plug-in detector board. Four different sensitivity and frequency settings for each loop. Sensitivity Boost feature, frequency counter, and Fast Trak feature for each loop. Loop 1 output is feed directly into control board; loop two output is via a dry contact relay. Manufactured by DoorKing Inc.
9401-045	Megohm meter. Checks integrity of ground loops. Reads up to 500 megohms.
2600-771	Asphalt sealant, flat black, 10 oz. tube
2600-772	Concrete sealant, gray, 10 oz. tube.
9401-060	Pre-fabricated ground loop (BLUE), 24 foot circumference with 50-foot lead-in cable. Loop consist of three turns of THHN insulated 18 AWG stranded wire enclosed in PLIOVIC tubing allowing it to be formed to the size and shape required. A "T" connector allows the lead-in wire to be routed through a 1/2 inch PVC conduit.
9401-061	Pre-fabricated ground loop (BLACK), 24 foot circumference with 50-foot lead-in cable. Loop consist of three turns of THHN insulated 18 AWG stranded wire enclosed in PLIOVIC tubing allowing it to be formed to the size and shape required. A "T" connector allows the lead-in wire to be routed through a 1/2 inch PVC conduit.
9401-062	Pre-fabricated ground loop (RED), 24 foot circumference with 50-foot lead-in cable. Loop consist of three turns of THHN insulated 18 AWG stranded wire enclosed in PLIOVIC tubing allowing it to be formed to the size and shape required. A "T" connector allows the lead-in wire to be routed through a 1/2 inch PVC conduit.

XLPE LOOP WIRE – ORDER BY PART NUMBER			
COLOR	BLACK	BLUE	RED
500 FEET	9402-076	9402-078	9402-080
1000 FEET	9402-077	9402-079	9402-081

